

Rotary heat pump

J. Juodvalkis*, E. Blaževičius**, J. Karbauskaitė***, V. Nenorta****

*Institute of Architecture and Construction of Kaunas University of Technology, Tunelio 60, 44405, Kaunas, Lithuania, E-mail: jonajus@gmail.com

**Institute of Architecture and Construction of Kaunas University of Technology, Tunelio 60, 44405, Kaunas, Lithuania, E-mail: asi@asi.lt

***Institute of Architecture and Construction of Kaunas University of Technology, Tunelio 60, 44405, Kaunas, Lithuania, E-mail: jukarb@asi.lt

****Kaunas University of Technology, Kęstučio 27, 44312 Kaunas, Lithuania, E-mail: vidmantas.nenorta@ktu.lt

1. Introduction

Wide application of renewable energy sources is predicted in the future energy industry. Regeneration of heat energy of higher potential from air, ground, water, or other energy sources with low energy potential on the base of thermo-dynamic processes in heat pumps could serve as one of such application possibilities. This heat energy could be supplied to heating systems in buildings with primary energy consumption a few times in amount less in comparison with the traditional energy supply systems where fuel is burnt.

Intensive research projects are provided and new ideas are carried out in this area with the aim to improve the efficiency of rotary heat pumps with the application of heat pipes and their structures, to ensure more reliable service life of them [1-5]. An original rotary heat pump suggested by the authors is discussed in the presented paper. All the thermo-dynamic processes of the suggested heat pump (evaporation – compression – condensation) based on the principle of heat pipe are provided in one volume of mushroom form closed vessel.

Three components of the new type are applied in the suggested heat pump: hydro-dynamic pump, disk ventilator [6, 7], and regeneration heat exchanger. All the components are involved into one integral unit.

No real analogue during the provided patent search were found. Heat pumps of similar structure have been found, but they are composed of separate elements (heat exchanger, radial ventilator, pumps) which are joined into a working unit [8-15].

2. Reasoning

Cooling effect is observed in [16]. It is known that at air (gas) flow supply with a certain velocity by tangential direction into a tube, exhaust air temperature T_s is decreased along the tube axis, $T_p > T_0 > T_s$, as it is depicted in Fig. 1.

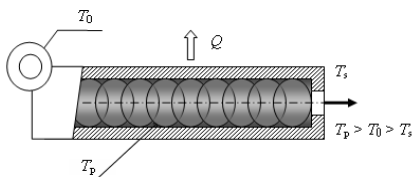

Fig. 1 Scheme of vortex tube: T_0 – supply air temperature, T_p – air temperature at the tube inside surface, T_s – exhaust air temperature

At present this method of air (gas) cooling is not widely applied due its insufficient efficiency whereas the main part of air (gas) flow energy is lost at friction.

Efficiency of the considered vortex tube could be increased by rotation of the tube together with the air in it. The action of suggested heat pump (heat pipe) is based on the above mentioned principle (scheme in Fig.2). The closed vessel of mushroom form 1 is filled with the vapor of working fluid (ammonia, freon, propane or other liquid). The vessel is rotated about its longitudinal axis at the certain rotational speed ω_0 . The working fluid is compressed in the wide part of the vessel because of centrifugal force. Temperature and pressure of the working fluid are increased at the inside surface of the vessel

$$T_k > T_a; \quad p_k > p_a \quad (1)$$

where T_a is temperature of the working fluid, T_k is temperature of the working fluid in the condensation zone, p_k is pressure in condensation zone; p_a is pressure of the working fluid.

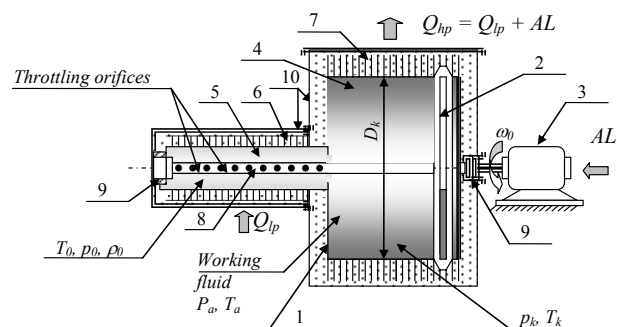

Fig. 2 Principle scheme of rotary heat pump: 1 - closed cylinder vessel of mushroom form (heat pipe); 2 - hydro-dynamic pump; 3 - electric motor; 4 - rotary compressor; 5 - evaporator of working fluid; 6, 7 - disk ventilator (pump); 8 - supply pipe of liquid working fluid; 9 - supporting bearings; 10 - heat pump envelope

At cooling of external surface of considered cylinder wide part, the heat energy of higher potential Q_{hp} is obtained. As a sequence, then the working fluid vapor will condense. The liquid fluid is returned into narrow part 5 of the vessel by hydro-dynamic pump 2. The returned liquid fluid is sprayed out through the throttling orifices onto internal surface of the evaporator. Temperature and pressure of the working fluid are decreased due to the throttling and

evaporation of the fluid is processed at temperature T_0 and pressure p_0 . The energy of low potential Q_{lp} is absorbed from environment during the evaporation process. This means energy transformation of low potential into the energy of higher potential at rotation of heat pipe.

2.1. Main parameters of working fluid

At the moment of isothermal compression of the working fluid vapor, the main parameters can be determinate as [16].

a) Pressure of the working fluid in condensation zone

$$p_i = p_0 \exp\left(\frac{1}{2} \cdot \frac{\omega_0^2 r_k^2}{gRT_0}\right) \quad (2)$$

where p_0 is working fluid pressure in evaporation zone; ω_0 is rotation speed of the vessel; R is gas constant; g is gravitational acceleration, m/s^2 ; r_k is characteristic dimension of the vessel (radius), m .

$$r_k = 0,5 D_k \quad (3)$$

where D_k is diameter of the disk pump, m .

b) Temperature of working fluid $T_i = T_0 = const$. where T_i is working fluid temperature in condensation zone.

c) Compression work

$$l_i = \frac{m_0 r_k^2}{6} \omega_0^2 \exp\left(\frac{1}{2} \cdot \frac{\omega_0^2 r_k^2}{gRT_0}\right) \quad (4)$$

where l_i is compression work of the working fluid; m_0 is mass of the working fluid in the closed vessel.

At the moment of adiabatic and poly-tropic compression of the working fluid vapor, the main parameters can be determinate as [16].

a) Pressure of the working fluid in condensation zone

$$p_k = p_0 \left[1 + \frac{(k-1)\rho_0 \omega_0^2 r_k^2}{2kgp_0} \right]^{\frac{k}{k-1}} \quad (5)$$

where ρ_0 is working fluid density in the evaporation zone; k is exponent of adiabatic process.

b) Working fluid temperature in condensation zone

$$T_k = T_0 + \frac{(k-1)\omega_0^2 r_k^2}{2kgR} \quad (6)$$

c) Compression work

$$l_k = \frac{1}{3k} m_0 r_k^2 \omega_0^2 \left[1 + \frac{\rho_0 \omega_0^2 r_k^2}{6gp_0} \right] \quad (7)$$

At poly-tropical process $k = n$; (n is exponent of poly-tropical process).

A supplementary power is necessary for kinetic

energy increment of the vessel with the working fluid at the start of rotary heat pump while the heat pipe is rotated up to the appointed rotation speed. As mass of the working fluid is not homogeneous during rotation of the rotor and depends on distance r from the rotation axis, inertia moment of the vessel is variable and should be expressed by the equation

$$I = \int_0^{r_k} r^2 dm \quad (8)$$

where r is distance of cylindrical layer of the working fluid from rotation axis; r_k is characteristic dimension of the vessel (radius), as in considered case it is equal to the distance of working fluid boundary layer from the axis of rotation; dm is increment of the working fluid mass in regard to rotation radius and is equal

$$dm = f(r) \quad (9)$$

Inertia moment of rotated vessel at appointed rotation speed ω_0 is dependent on compression kind of working fluid:

a) in the case of isothermal compression of the working fluid vapor

$$I_i = \frac{m_0}{r_k} \int_0^{r_k} \exp\left(\frac{\omega_0^2 r^2}{2gRT_0}\right) \quad (10)$$

b) in the case of adiabatic and poly-tropic compression of the working fluid vapor

$$I_k = \frac{m_0}{r_k} \int_0^{r_k} \left[1 + \frac{(k-1)\rho_0 \omega_0^2 r^2}{2kgp_0} \right]^{\frac{1}{k-1}} \quad (11)$$

At poly-tropical process $k = n$; (n is exponent of poly-tropical process).

The advantages of rotary heat pump:

1) compact structure – all the thermal processes of the working fluid (compression, condensation, throttling down and evaporation) are provided in one unit;

2) heat is transferred (absorbed) from cylindrical vessel surfaces by disk ventilators of a new type;

3) no sliding movement parts in the unit volume;

4) engineering technology of the product is quite simple;

5) prior field of application – endo-thermal heating systems in buildings;

6) the liquid working fluid is returned into evaporation zone by hydro-dynamic pump.

3. The elements of rotary heat pump

The three components of a new type are foreseen to be applied in the suggested principally different heat pump:

1. hydro-dynamic pump (Fig. 3);

2. disk ventilator (pump) (Fig. 4 and Fig. 7);

3. regeneration heat exchanger (Fig. 8).

3.1. Hydro-dynamic pump

Operation of the suggested hydro-dynamic pump is different from widely used ones at present. It is based on

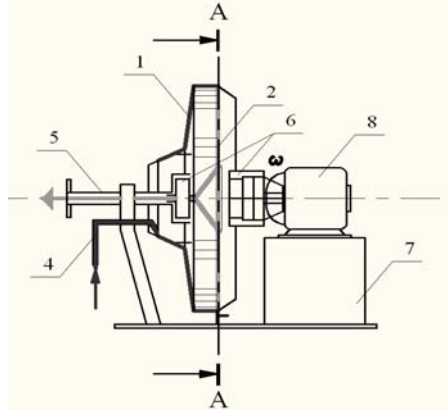

Fig. 3 Principal scheme of hydro-dynamic pump: 1 - rotary body of the pump; 2 - stationary impeller (stator); 3 - Pitot tube (in impeller supporting structure); 4 - fluid pick-up pipe; 5 - fluid pressure pipe; 6 - bearings; 7 - support stand; 8 - motor; ———> - high pressure fluid tract; ———> - low pressure fluid tract

The impeller (stator) of the hydro-dynamic pump is not turning on, as it is stopped down by the gravity forces. Afterwards working fluid with a certain kinetic energy is passed into Pitot tube 3 and through it into the central part of the impeller with the following pass into the external net. Then the working fluid is spread on inside surface of the rotated cylinder vessel and forwarded to its periphery. The flow of the working fluid in the rotated vessel by thin layer is moved into periphery and regime of the flow is close to laminar. Here energy is not lost for the maintenance of turbulent flow in the working volume (in opposite to centrifugal and axial pumps etc.). The dynamic pressure in Pitot tube is transformed into static pressure. The energy is lost by friction at the hydraulic boundary layer and flow drag in the Pitot tube.

The work necessary for fluid cranking up to the peripheral speed v_p

$$L_i = \frac{mv_p^2}{2} - \frac{mv_{p0}^2}{2} \quad (12)$$

where L_i is the work due to cranking of the fluid, J; m is fluid rate in the pump, kg/s; v_p is fluid velocity at pass into Pitot tube m/s; v_{p0} is fluid velocity at the pump inlet, m/s.

The work necessary for fluid stopping in Pitot tube

$$L_s = \frac{mv_p^2}{2} - \frac{mv_i^2}{2} \quad (13)$$

where L_s is the work due fluid stopping, J; v_i is fluid velocity at the pump outlet, m/s. Then the energy consumed at pump operation (power)

$$L = \left(\frac{mv_p^2}{2} - \frac{mv_{p0}^2}{2} \right) + \left(\frac{mv_p^2}{2} - \frac{mv_i^2}{2} \right) \quad (14)$$

$$\eta N_s = \frac{m}{2} (2v_p^2 - v_{p0}^2 - v_i^2) \quad (15)$$

the effect of Pitot tube, when pressure is determined as static pressure p_k in the compression zone and dynamic pressure component p_d in the periphery fluid layer (Fig. 3).

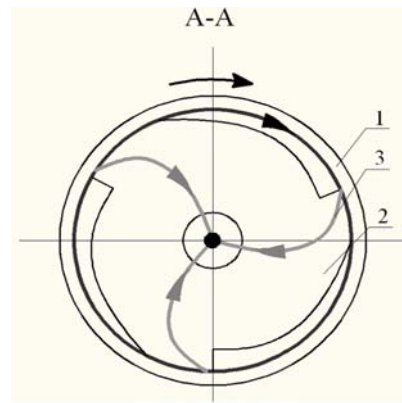

where L is energy consumed in the pump, J; N_s is power of the pump, J/s (W); η is efficiency of the pump.

3.2. Disk ventilator

Operation principle of the disk ventilator or the pump action (Fig. 4) is based on the effect of fluid (gas) flow stopping at hydraulic boundary layer. Hydraulic boundary layer is distinguished by fluid flow laminar regime in the channels of any shape. Heat transfer through such layer is provided due to heat conduction only. So boundary layer formed on the disks surfaces is detached by partition having the form of comb and placed between the disks up to axis during the turn of the device.

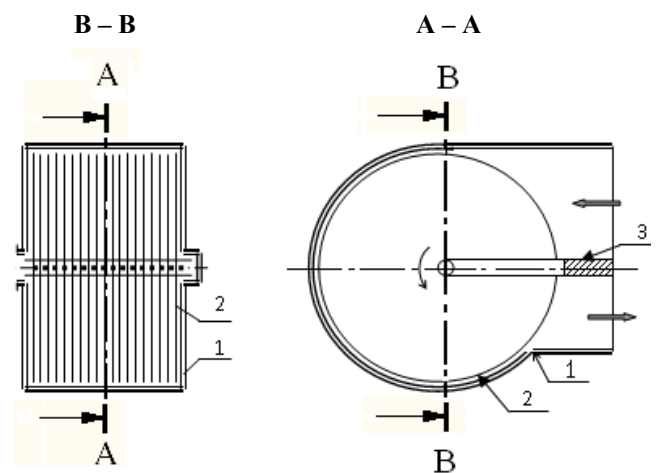

Fig. 4 Disk ventilator: 1 - ventilator body; 2 - impeller of disk shape (rotor); 3 - partition of the comb shape

The hydraulic boundary layers formed on the disks surfaces are trailing working fluid (gas) layers located at some distance from the disks surfaces. The partitions between the disks are diverting the fluid into the outlet channel. In practice, the fluid is left in the space between the disks during one turn. The energy is not consumed for maintenance of fluid turbulence in the pump

volume in comparison with the centrifugal pumps. The regime of fluid flow between the blades is close to laminar regime.

Theoretical research of the suggested pump is not carried out. The special method for efficiency assessment of technology parameters and the structure is not developed also. The tests of laboratory made samples of ventilator as well as the pump gave positive results. The image of one tested disk pump prototype is presented in Fig. 5. The main characteristic obtained by the tested sample is presented in Fig. 6.

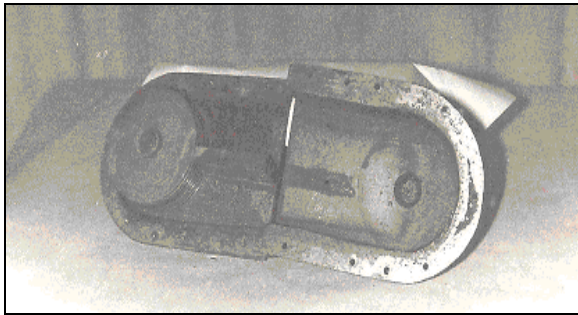

Fig. 5 Image of disk pump prototype (cover removed)

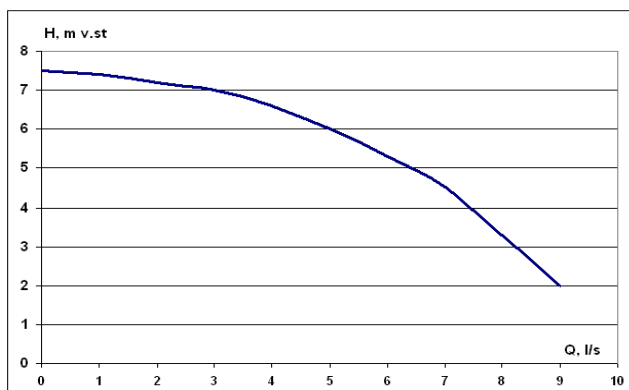

Fig. 6 Measured Q - H characteristic of the tested disk pump prototype: Q is supply water rate by the pump, l/s, H is supply water pressure by m of the water lift

The fluid flow between the disks in the considered disk pump is actuated by hydraulic traction force of the boundary layer. Flows of turbulent shape between the blades (disks) are decreased to the minimum and the power necessary for the pump is less by 15 - 20% in comparison to centrifugal pumps. Vacuum is formed in the lower part of the partition (with respect to rotation direction) and a certain suction force is created by the pump. This means that operation of considered disk pump could be in the regime of suction or compression as well. Distance between the disks is depending on viscosity of the working fluid and could be selected for a wide range of the working fluid in regard to its viscosity.

The pump output could be easily changed by assembling the rotor of a proper size by certain sections. The enlargement of generated of the pump pressure is possible by joining of two or more pumps into cascade [7]. The image of disk ventilator test sample is given in Fig. 7.

3.3. Regeneration heat exchanger

The operation of considered heat exchanger is

based on the principle of the rotary heat pipe (Fig. 8). The disk pumps (ventilators) are mounted on rotary heat pipe. They transport working fluid and are acting as heat exchangers. The joint heat and working fluid mass transfer is rational and could be foreseen in some kind of equipment applied in endo-thermal heating systems [17].

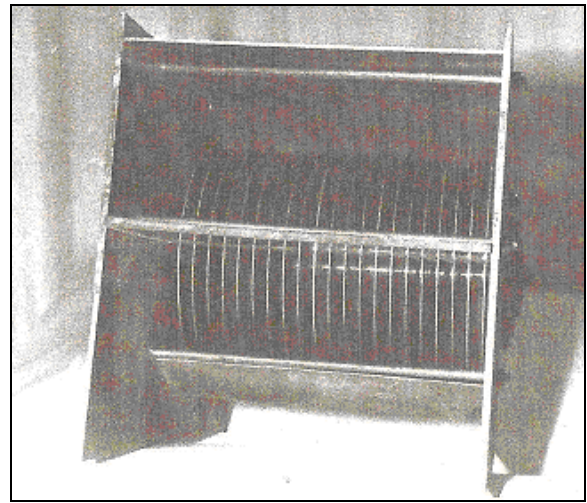

Fig. 7 Image of disk ventilator test sample

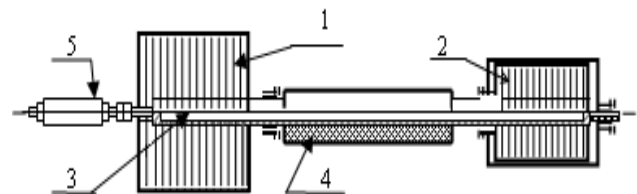

Fig. 8 Scheme of regeneration heat exchanger: 1 – disk ventilator (pump) for heat outcome; 2 – disk pump (ventilator) for heat absorption; 3 – rotary heat pipe (partially filled by fluid with a certain boiling temperature); 4 – thermal insulation of connecting link; 5 – motor

4. Conclusions

1. Suggested rotary heat pump belongs to the equipment of a new structure and is foreseen to be applied in endo-thermal heating systems, especially in air heating.

2. All the thermal processes are coupled in one unit of rotary heat pump. The same processes regarding heat pumps of traditional shape are usually provided in separate components of the considered heat pump.

3. Structure of the suggested heat pump is simple and production of it should be easily arranged. There are no parts of sliding movement in the structure.

4. The three components of a new type are applied in the structure of the suggested heat pump (hydrodynamic pump, disk pump (ventilator) and regeneration heat exchanger).

References

1. Song, F.; Ewing, D.; Ching, C.Y. 2004. Experimental investigation on the heat transfer characteristics of axial rotating heat pipes, International Journal of Heat and Mass Transfer, Volume 47, Issue 22: 4721-4731.
2. Song, F.; Ewing, D.; Ching, C.Y. 2008. Heat transfer

- in the evaporator section of moderate-speed rotating heat pipes, *International Journal of Heat and Mass Transfer*, Volume 51, Issues 7-8: 1542-1550.
3. **Jacobi, M.; Shah R.K.** 1995. Heat transfer surface enhancement through the use of longitudinal vortices: A review of recent progress, *Experimental Thermal and Fluid Science*, Volume 11, Issue 3: 295-309.
 4. **Behcet, R.; Yakut, A.K.; Argunhan, Z.** 2011. The effect of rotary type turbulator placed in entrance of heat exchanger on heat transfer and frictional loss, *Energy Education Science and Technology Part A-Energy Science and Research*, Volume: 28, Issue: 1: 239-248.
 5. **Sarac, B.A.; Bali T.** 2007. An experimental study on heat transfer and pressure drop characteristics of decaying swirl flow through a circular pipe with a vortex generator, *Experimental Thermal and Fluid Science*, Volume: 32, Issue: 1: 158-165.
 6. **Juodvalkis, J.** Disk Type Ventilator. Authorship Certificate No. 98544, 04.01.1981 (in Russian).
 7. **Juodvalkis, J.** Friction (disk type) Pump. Authorship Certificate No. 1044827, 01.06.1983 (in Russian).
 8. Heat Exchanger for Cooling and Method of Servicing Same. USA Patent No. 5035281, 30.07.1991, class F28D15/00.
 9. Heat Pipe Heat Amplifier. USA Patent No. 416554, 15.08.1978, class AF25B1500F1.
 10. Rotary Absorption Heat Pump. Description of the USA Patent, IPC8, class AF25B1500F1.
 11. Bombs of Heat. Spain Patent No. ES2103258T3, 23.01.1989, class F25B15/06 (in Spain).
 12. Termal Heat Pump. USA Patent No. 4281709, 04.08.1981, class F28D15/00.
 13. Rotary Heat Absorption Heat Pump of Improved Performance. USA Patent No. 5303565, 19.04.1994, class F28D15/00.
 14. Rotary Heat Pump Exchangers. European Patent No. 05227474A1, 24.06.1992, class F28D15/02.
 15. Rotary Trisorption Heat Pump. USA Patent No. 5279359, 18.01.1994, class F25B17/04.
 16. Thermal Technique, Guide, vol.1, Energy, Moscow, 1975, p. 429 (in Russian).
 17. **Juodvalkis, J; BlazeVICIUS, E; KarbaUSkaite, J.** 2011. Investigation of endo-thermic heating in buildings, *Energetika*, t.57, Nr. 2: 95-100 (in Russian).

J. Juodvalkis, E. Blaževičius, J. Karbauskaitė, V. Nenorta

ROTACINIS ŠILUMOS SIURBLYS

Reziumė

Straipsnyje aptariamas autorių siūlomas originalus rotacinis šilumos siurblys, kuriame visi termodinaminiai darbo agento procesai (išgarinimas-suspaudimas-kondensacija) vyksta šiluminio vamzdžio darbo principu viename uždarame grybo formos pavidalo indo tūryje. Jame, kaip vientisame elemente, yra suderintos ir išorinių šilumnešių transportavimo funkcijos. Darbo agentui išgarinti reikalinga šiluma šalinama diskiniu ventiliatoriumi. Šiame šilumos siurblyje naudojami trys naujo tipo mazgai: hidrodinaminis siurblys, diskinis ventiliatorius ir regeneracinis šilumokaitis.

J. Juodvalkis, E. BlazeVICIUS, J. KarbaUSkaite, V. Nenorta

ROTARY HEAT PUMP

Summary

An original rotary heat pump suggested by the authors is described in the presented paper. All thermodynamic processes of working fluid (evaporation – compression – condensation) based on the principle of heat pipe are provided in one volume of mushroom form closed vessel. The transportation of external heat flows is combined in the unit as well. The heat necessary for evaporation is taken from external heat sources, and heat produced by working fluid at condensation is transferred by disk type ventilators (authorship certificate No 98544, 04.01.1981). The three components of a new type are applied in the suggested heat pump: hydro-dynamic pump, disk ventilator, and regeneration heat exchanger.

Received March 11, 2011

Accepted October 21, 2011